



Woodworking Plans

4-H Key Holder

Materials needed

- 1 piece of 1 x 6 lumber (actual size $\frac{3}{4}$ " x $5\frac{1}{2}$ " x 11" long)
- 7 — $\frac{1}{2}$ " cup hooks
- Carbon paper
- Sandpaper (medium and fine grit)
- Paint (green and white)
- Stain
- Varnish

Tools needed

- Coping saw or saber saw
- Boring tool with $\frac{1}{8}$ " bit
- Woodburning tools (optional)

Instructions:

1. Trace pattern onto wood using carbon paper. (See instructions for grid enlargements on page 11.)
2. Cut out the key using the saw.
3. Drill $\frac{1}{8}$ " hole at top for hanging.
4. Sand the wood piece thoroughly.
5. Stain the piece.
6. Take the pattern and re-mark your wood for the 4-H Clover design and cup hooks.
7. Paint the clover green and the H's white. (Instead of using paint, you can burn the clover design into the wood with a woodburning tool.)
8. Varnish the entire item.
9. Install the hooks.

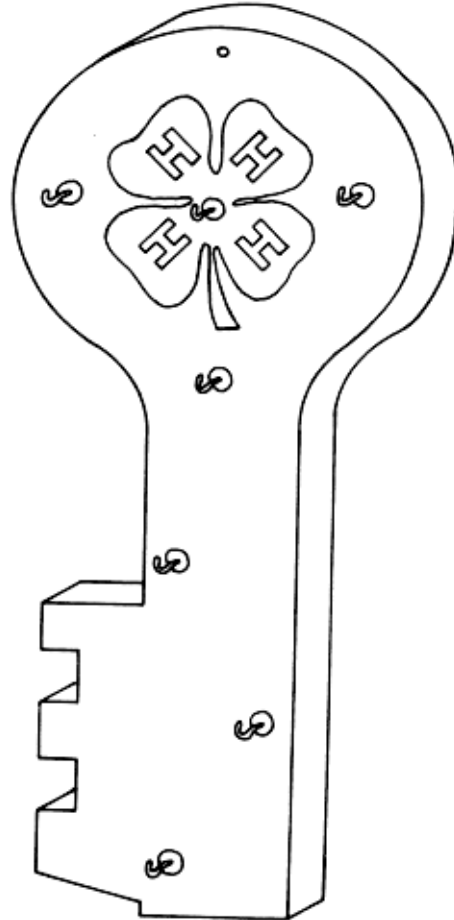



Cutting Board

Materials needed

- 1 piece of 1 x 8 hardwood (actual size $\frac{3}{4}$ " x $7\frac{1}{4}$ ") x 15" long
- Sandpaper (medium and fine grit)
- Varnish

Tools needed

- Pencil compass
- Square
- Saw (coping, jig, or saber saw)
- Boring tool with $\frac{1}{4}$ " bit

Instructions

1. Using the pencil compass, lay out curves and the hole in the handle on your wood piece. Use the square to make straight lines on the sides and end.
2. Cut out the curves and drill hole.
3. Sand both sides.
4. Finish with two or three coats of varnish, on one side only. (This process is optional.)

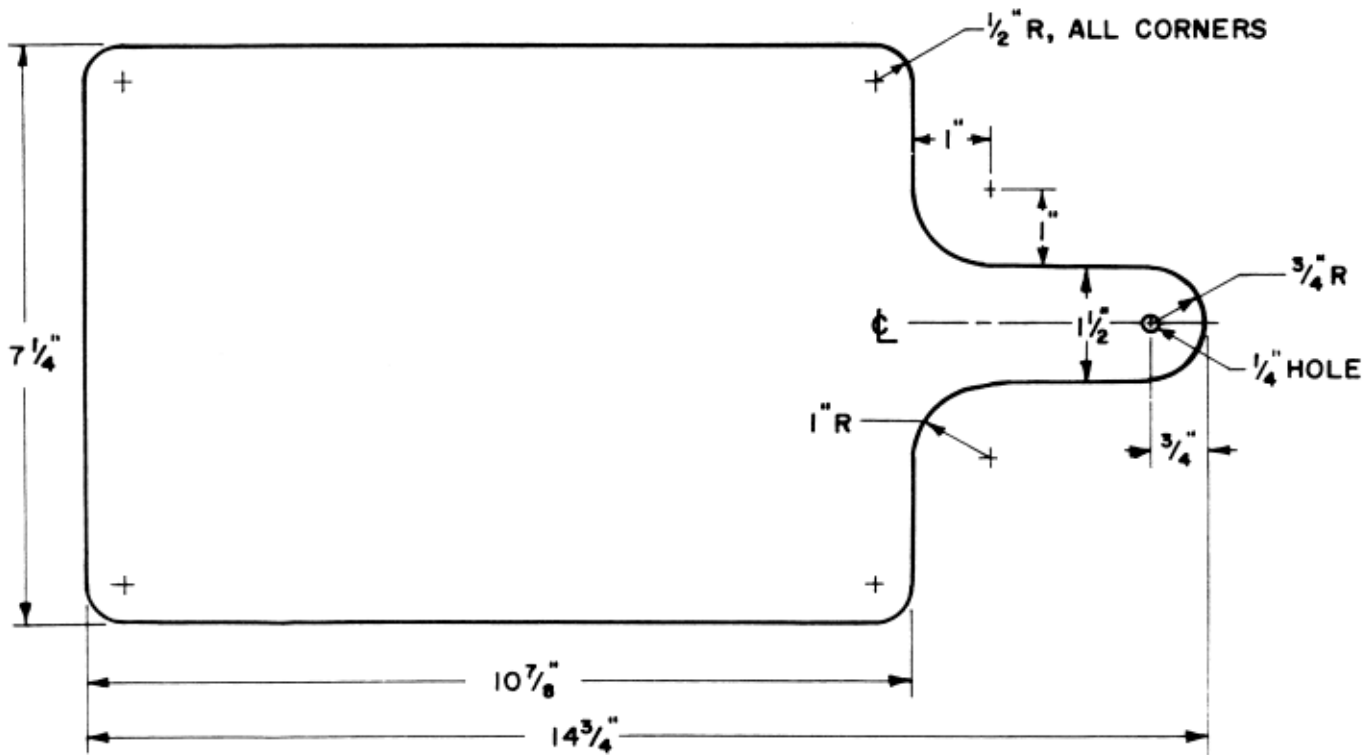



The Shifting Pyramid Game

Materials needed

- 1 piece of $\frac{3}{4}$ " x 8" x 8" A-D or better plywood, or use a piece of lumber 1 x 10 (actual size $\frac{3}{4}$ " x 9 $\frac{1}{4}$ ") x 8" long (base)
- 1 piece of $\frac{1}{4}$ " x 6" x 6" A-D or better plywood, or use a piece of lumber 1 x 8 (actual size $\frac{3}{4}$ " x 7 $\frac{1}{4}$ ") x 6" long (game pieces)
- 1 piece of $\frac{1}{4}$ " dowel stock, 12" long (pegs)
- Glue
- Sandpaper (medium and fine grit)
- Finishing material (optional)

Tools needed

- Saw (coping, saber or jig saw)
- Boring tool with $\frac{1}{4}$ " and $\frac{3}{8}$ " bits

Instructions

1. Trace the pattern for the base using carbon paper between your piece of wood and the pattern. Use the pattern on page 22.

NOTE: If your saw cuts on the pull stroke, trace your pattern on the back side of your wood piece so that the front face of the piece does not get damaged during cutting.

2. Cut out the base using a saw.
3. Mark and drill $\frac{1}{4}$ " peg holes, $\frac{1}{2}$ " deep in the base at the locations marked with an X.

4. Sand the surfaces and edges of the base.
5. Cut three pieces of the $\frac{1}{4}$ " dowel stock, 3" in length.
6. Sand the dowel pegs, rounding the top ends.
7. Apply glue to the sides of the holes with a small stick, then place the pegs in the holes.
8. Mark and cut the five movable pieces from the $\frac{1}{4}$ " plywood. Dimensions of the pieces are (3 x 3"), (2 $\frac{1}{2}$ " x 2 $\frac{1}{2}$ "), (2" x 2"), (1 $\frac{1}{2}$ " x 1 $\frac{1}{2}$ "), and (1" x 1"). These pieces can be cut round or square.
9. Mark the centers of each individual piece, and drill a $\frac{3}{8}$ " hole completely through the piece.
10. Sand each piece and finish with a material of your choice. Painting the pieces different colors adds eye appeal.

How to Play:

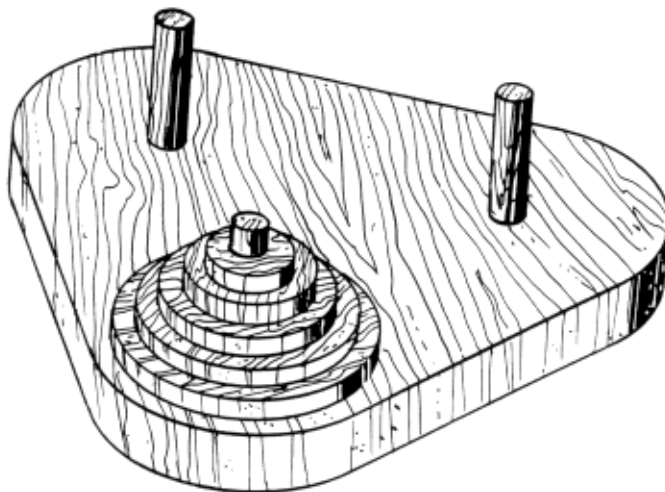



Place five pieces on one peg in pyramid formation. The object is to shift the entire pyramid (5 pieces) to another peg, moving one piece at a time and at no time having a larger piece above a smaller one. Can you do it in 31 moves (that's perfect)?

To make the puzzle more challenging, use seven blocks instead of five.

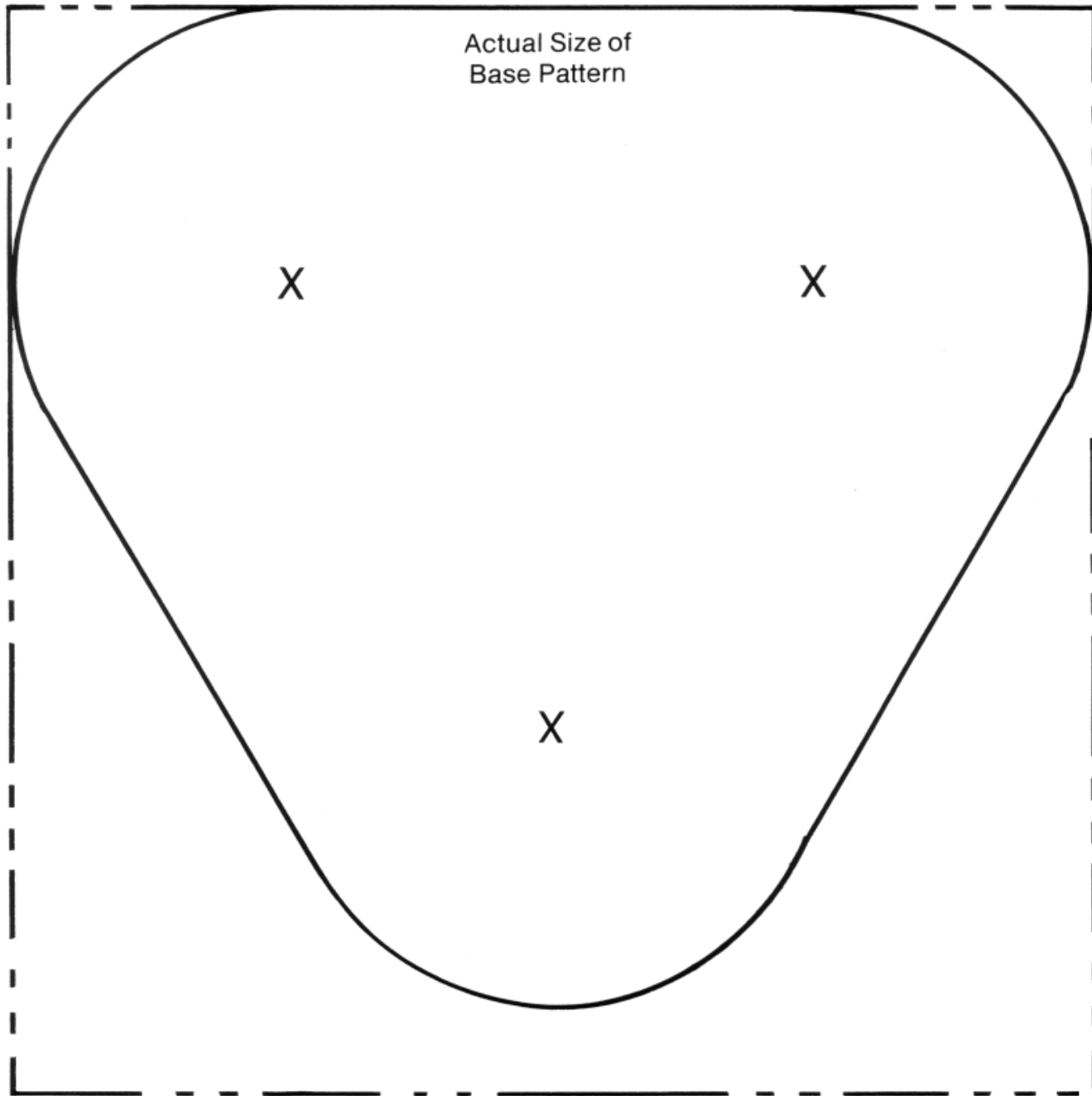



Bird House

Materials needed

- 1 piece of lumber 1 x 6 (actual size $\frac{3}{4}$ " x $5\frac{1}{2}$ ") x 54" long
- 1 piece of bevel siding or other material for roof $\frac{3}{4}$ " x 10" x 8"
- 1 piece of lumber 1 x 4 (actual size $\frac{3}{4}$ " x $3\frac{1}{2}$ ") x 4" long for coon and starling guard
- 3 — No. 10, $1\frac{1}{2}$ " round-head wood screws
- $1\frac{1}{4}$ " galvanized or aluminum nails for roof and guard
- $1\frac{3}{4}$ " to $2\frac{1}{4}$ " galvanized or aluminum nails
- Sandpaper (medium and fine grit)
- No finish is necessary for the bird house

Tools needed

- Square
- Hand saw
- Hammer
- Boring tool with $\frac{3}{8}$ " and $1\frac{1}{2}$ " bits (bird hole can be cut with a compass saw or saber saw instead of using a drill)
- Pilot hole bits to fit the screws
- File

Instructions

1. Mark and cut pieces as shown in the diagram below.
NOTE: One side of the house is hinged to pivot on screws for easy access for annual cleaning. Removal of the screw at the bottom of the side allows the top of the side to be pushed inward. The hinged side should be $\frac{1}{16}$ " shorter than the other side.
2. Sand pieces smooth.
3. Drill a $\frac{3}{8}$ " drain hole in each corner of the bottom.
4. Drill holes in the front and back pieces to accommodate the screws.
NOTE: Follow the instructions on page 17 for making pilot holes.
5. Assemble all pieces using nails, except for the hinged side.
6. Install hinged side using screws.

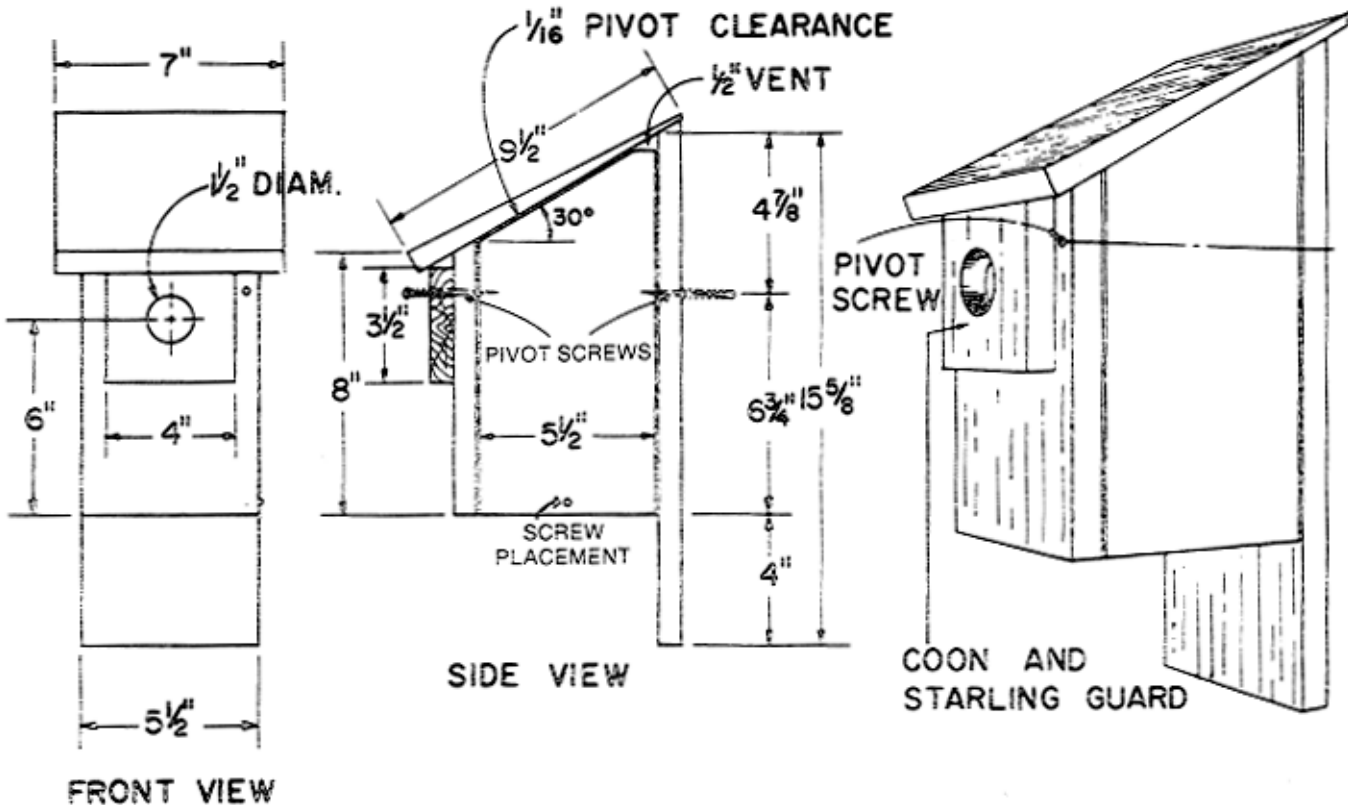



4-H Book Ends

Materials needed

- 1 piece of 1 x 6 lumber (actual size $\frac{3}{4}$ " x $5\frac{1}{2}$ ") x 36" long, or you can use interior-type plywood ($\frac{3}{4}$ " A-C grade or better)
 - 10 — 1 $\frac{1}{2}$ " finishing nails
 - Sandpaper (medium and fine grit)
 - Glue
- Paint and varnish, optional

Tools needed

- Saw (coping, jig, or saber)
- Hammer

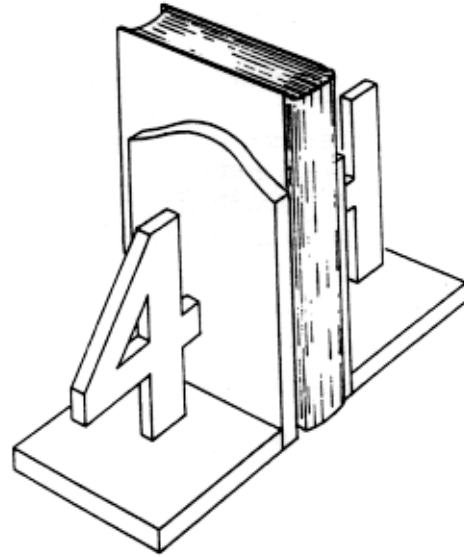

ACTUAL SIZE



4-H Book Ends (continued)

Instructions

1. Mark out two base pieces $5\frac{1}{4}$ " long. Mark out the end pieces (page 24) and the 4 and H below. They can be traced with carbon paper and pencil.
2. Cut out the pieces and sand smooth. Put together with $1\frac{1}{2}$ " finishing nails and glue.
3. Apply finish.

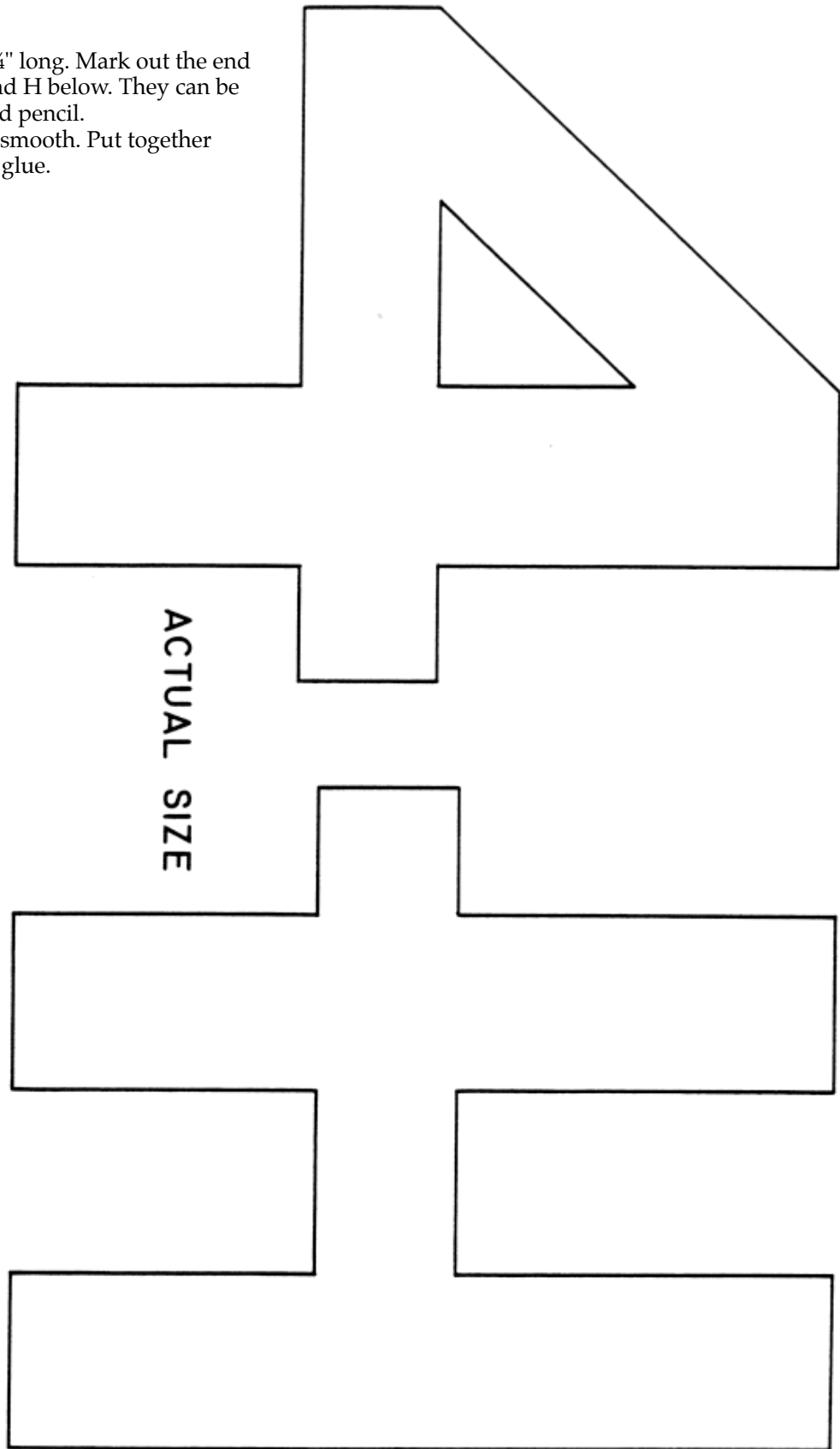



Foot Stool

Materials needed

- 1 piece of 1 x 8 lumber (actual size $\frac{3}{4}$ " x $7\frac{1}{4}$ ") x 24" long—for top and legs
- 1 piece of 1 x 4 lumber (actual size $\frac{3}{4}$ " x $3\frac{1}{2}$ ") x 12" long—for stretcher
- 8 — No. 8, $1\frac{1}{2}$ " flathead wood screws
- Sandpaper (medium and fine grit)
- Glue

Tools needed

- Hand saw
- Screwdriver
- Boring tools
- Pilot hole bits to fit the screws and countersink

Instructions

1. Measure and mark the pieces for the footstool.
2. Cut out the pieces.
3. Drill holes for the screws and countersink them so that the screwheads are just below the wood surface.
4. Sand the pieces.
5. Assemble with glue and the screws.
6. Finish as desired.

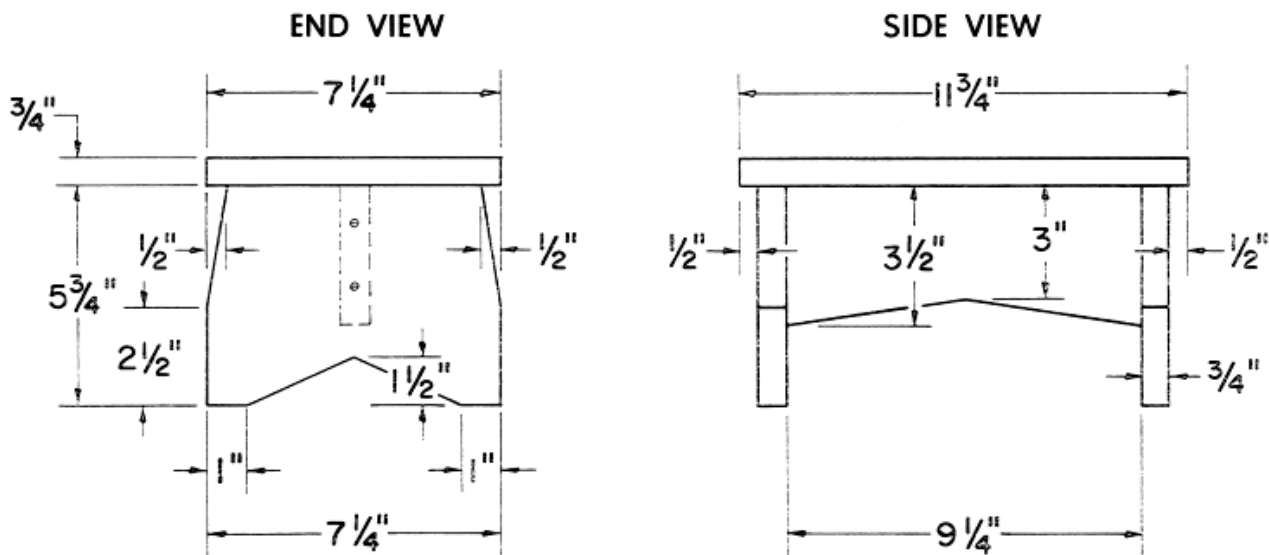
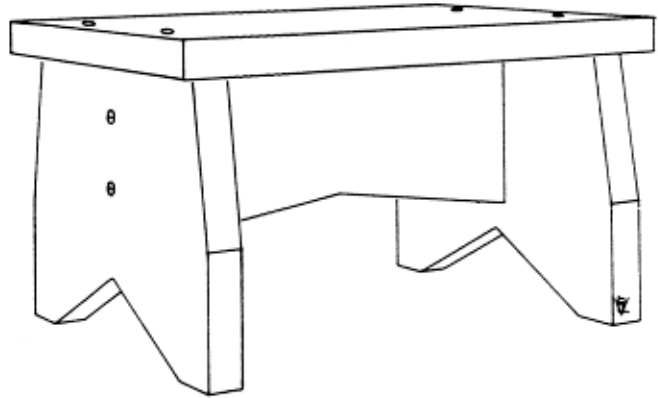



Book Rack

Materials needed

- 1 piece of 1 x 8 lumber (actual size $\frac{3}{4}$ " x $7\frac{1}{4}$ ") x 18" long (bottom)
- 1 piece of lumber 1 x 6 (actual size $\frac{3}{4}$ " x $5\frac{1}{2}$ ") x 18" long (back)
- 1 piece of 1 x 8 lumber (actual size $\frac{3}{4}$ " x $7\frac{1}{4}$ ") x 16" long (L-shape ends)
- 13 — No. 6, $1\frac{1}{4}$ " flat-head wood screws
- Stain and varnish (optional)

Tools needed

- Hand saw
- Screwdriver
- Boring tool with a $\frac{1}{8}$ " bit and countersink

Instructions

1. Cut pieces to size, including the two L-shaped ends.
2. Sand pieces smooth.
3. Drill and countersink five holes, 3 inches apart, $\frac{3}{8}$ " from the edge on a long edge of the 1 x 8 x 18" piece.
4. Screw the 1 x 6 x 18" piece to the 1 x 8 x 18" piece using five of the wood screws.
5. Mark, drill, and countersink the four holes in each L-shape end.
6. Screw the L-shape ends to the ends of the shelf assembly using two screws on each end.
7. Stain and varnish or finish as desired.

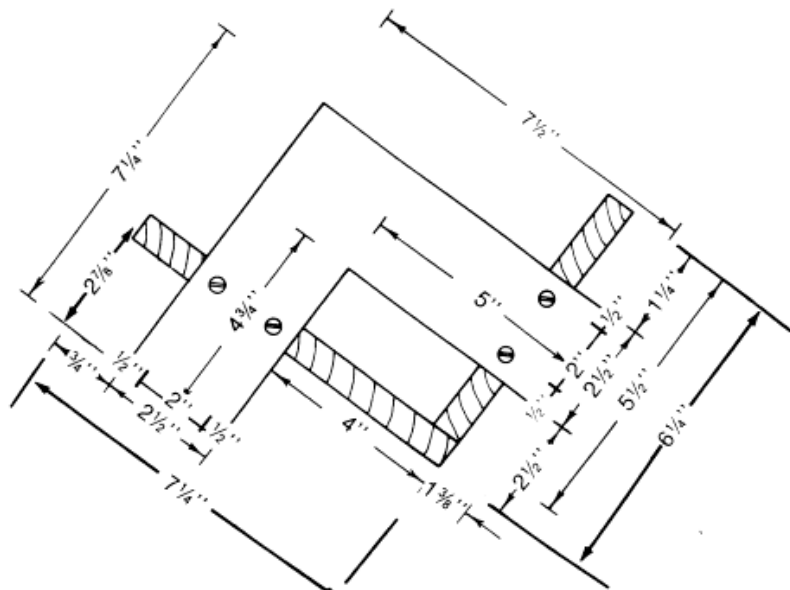
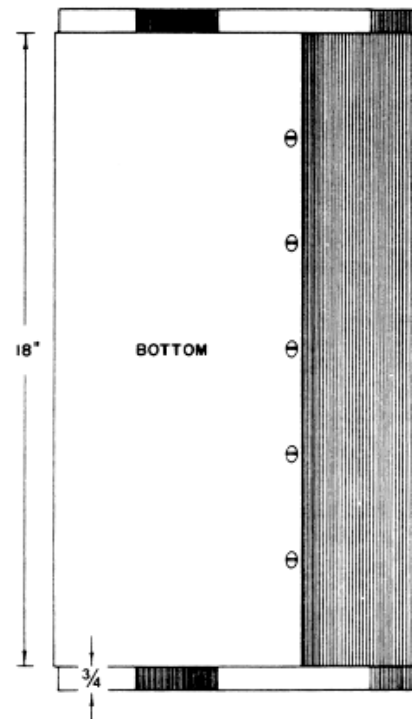
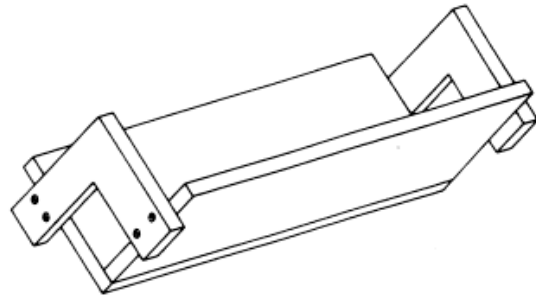



Tool Box

Materials needed

- 2 pieces of 1 x 4 lumber (actual size $\frac{3}{4}$ " x $3\frac{1}{2}$ ") x 18" long—sides
- 2 pieces of 1 x 4 lumber (actual size $\frac{3}{4}$ " x $3\frac{1}{2}$ ") x 10" long—ends
- 1 piece of 1 x 8 lumber (actual size $\frac{3}{4}$ " x $7\frac{1}{4}$ ") x 18" long—bottom
- 1 piece of 1 x 6 lumber (actual size $\frac{3}{4}$ " x $5\frac{1}{2}$ ") x 18" long—handle
- 4 — No. 8, $1\frac{1}{2}$ " flat-head wood screws
- 25 — No. 8, 2" flat-head wood screws
- Sandpaper (fine grit)

Tools needed

- Saws (hand saw and coping, jig, or saber saw)
- Screwdriver
- Round wood rasp or file
- Boring tool with a 1" bit
- Pilot hole bits to fit the screws and countersink

Instructions

1. Cut pieces to size. (See diagram on page 29.)
2. Mark the angled cuts on the handle as shown in the diagram. Cut the angles with the saw, leaving $\frac{1}{16}$ " or so for sanding.
3. Mark the handle hole. Bore a 1" hole at each end of the mark and remove the rest with a coping saw. Use a round wood rasp or file to even the handle edges. Sand the handle smooth.

4. Draw the center line lengthwise on the 1 x 8 x 18" bottom piece. Drill and countersink holes every 3 inches on that line and screw the handle to the bottom using 2" wood screws.

NOTE: Follow the instructions for drilling pilot holes on page 17. Countersink the holes on the outside of the tool box so the heads of the screws are slightly below the surface of the wood. A careful craftsman lines the slots of the screws so that they are all in the same direction.

5. Drill and countersink holes in the two 1 x 4 x 18" side pieces, $\frac{3}{8}$ " from the bottom edge. Space the holes as shown in the diagram. Now screw both sides to the edges of the bottom piece using 2" screws.
6. Add the ends in the same manner, except use $1\frac{1}{2}$ " screws in the bottom corners of each piece.
7. For added strength, drill and countersink three holes in each end piece to hold the handle. Space them as shown in the diagram, and insert a 2" screw in each hole.

NOTE: This tool box is approximately $8\frac{3}{4}$ " wide. This measurement may need to be adjusted to the width and thickness of your bottom and side pieces.

